



Formatec S.R.L.
Industrial



Carbone  *Hardware*

Sistema Slider

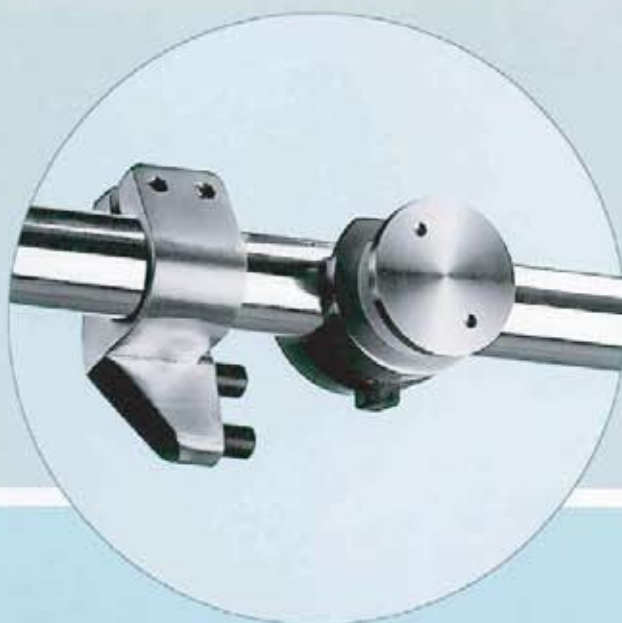

Formatec Industrial S.R.L.

<http://formatecsrl.com.ar/>

RODAMIENTO PARA SISTEMA SLIDER CON TOPE DE SEGURIDAD

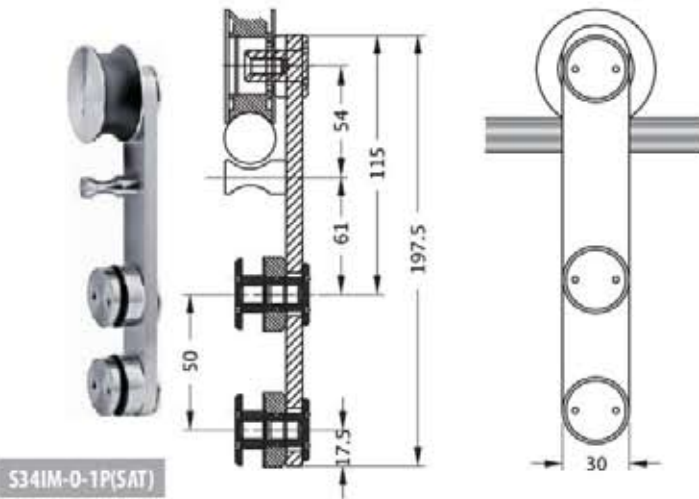

Detalle de Perforaciones

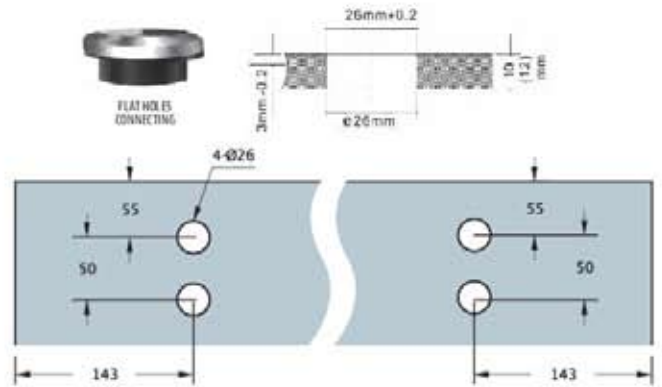

SOPORTE PARA PARED

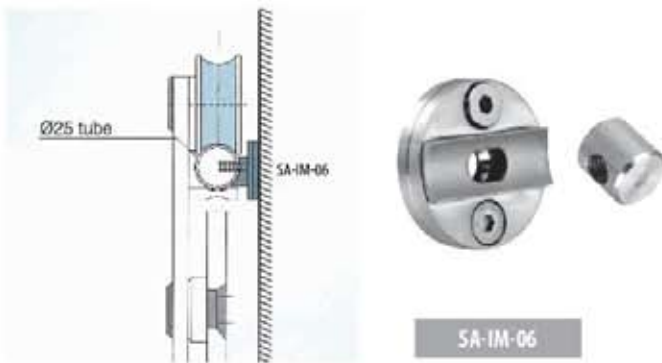

SOPORTE PARA VIDRIO

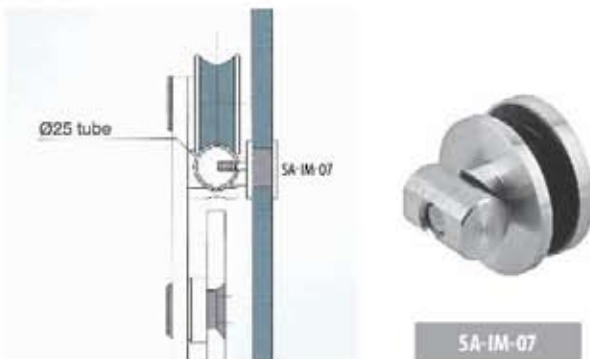

RODAMIENTO SISTEMA SLIDER (UNIDAD)

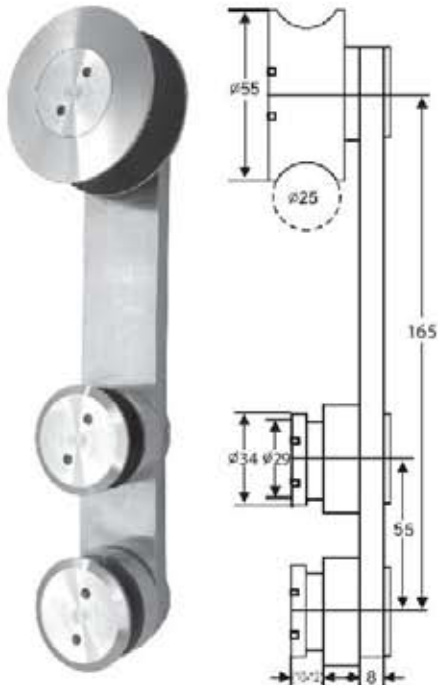

El vidrio requiere
2 agujeros planos de 26 mm

A8300A-1

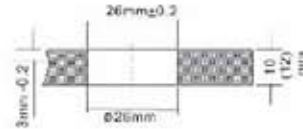

FLAT HOLES
CONNECTING

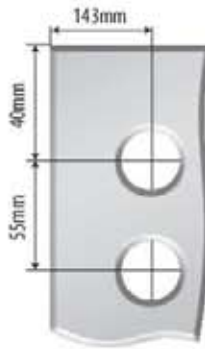

SOPORTE TUBO - PARED

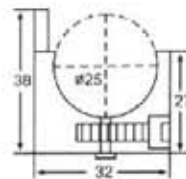

A8300A-2

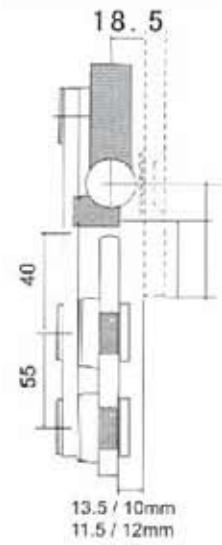

SOPORTE TUBO - VIDRIO

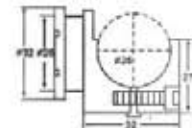

El vidrio requiere 1 agujero
plano de 26 mm

A8300A-3

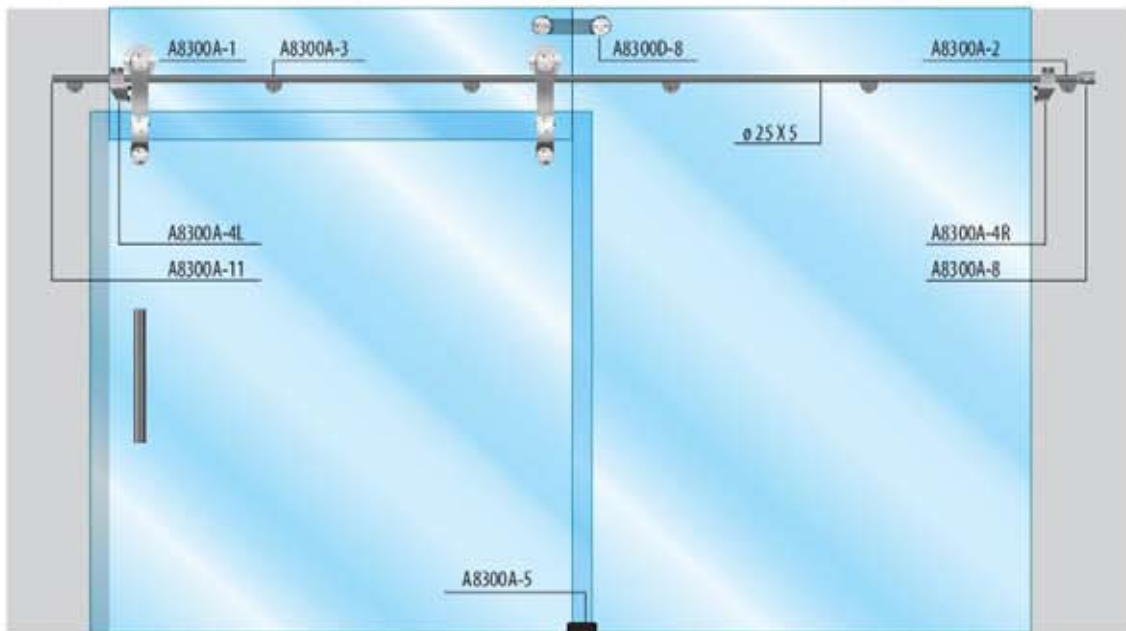

TOPE IZQUIERDO



A8300A-4 LEFT

TOPE DERECHO



A8300A-4 RIGHT



TUBO REDONDO DE 25 MM X 2 MM

6 metros de largo



A-TUBO SLIDER

CONECTOR TUBO PARED

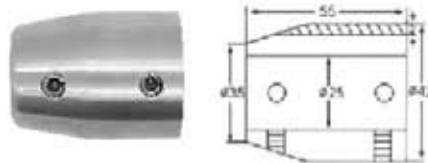

A8300A-8

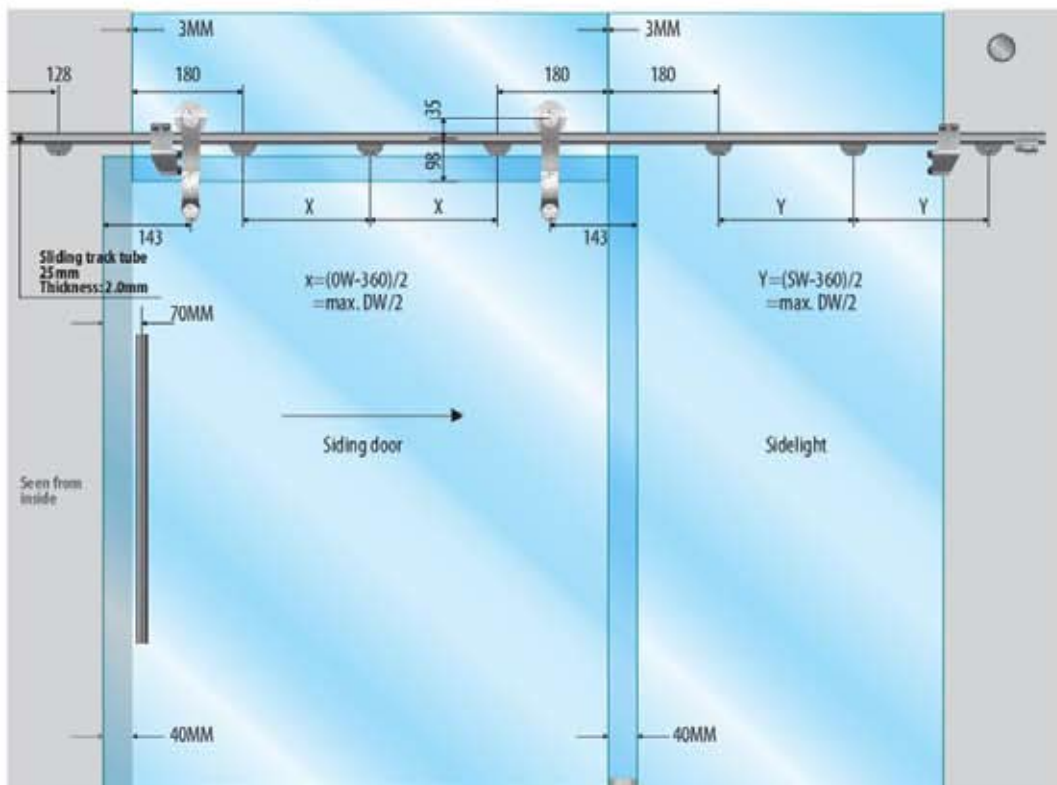
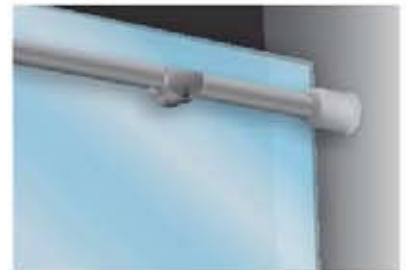

Detalle técnico de instalación

TIRADOR PLANO

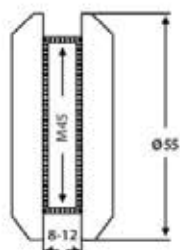

Perforación en vidrio de 50 mm

A9300A-4

CONECTOR VIDRIO-VIDRIO

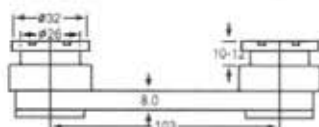

A8300D-8

CERRADURA ESPECIAL PARA SISTEMA SLIDER

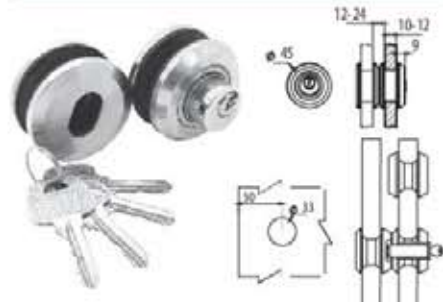

Perforación en vidrio de 33 mm

TD-8600A-13

GUÍA DE PVC

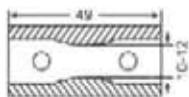

A8300A-5

TAPA PARA TUBO SLIDER

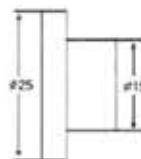

A8300A-11



GUÍA DE ACERO INOXIDABLE

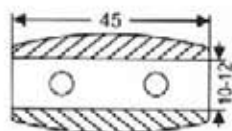

A8300A-5 SS



Sistema
Tech-Slide 1.0



Formatec Industrial S.R.L.

<http://formatecsrl.com.ar/>



Formatec Industrial S.R.L.

<http://formatecsrl.com.ar/>

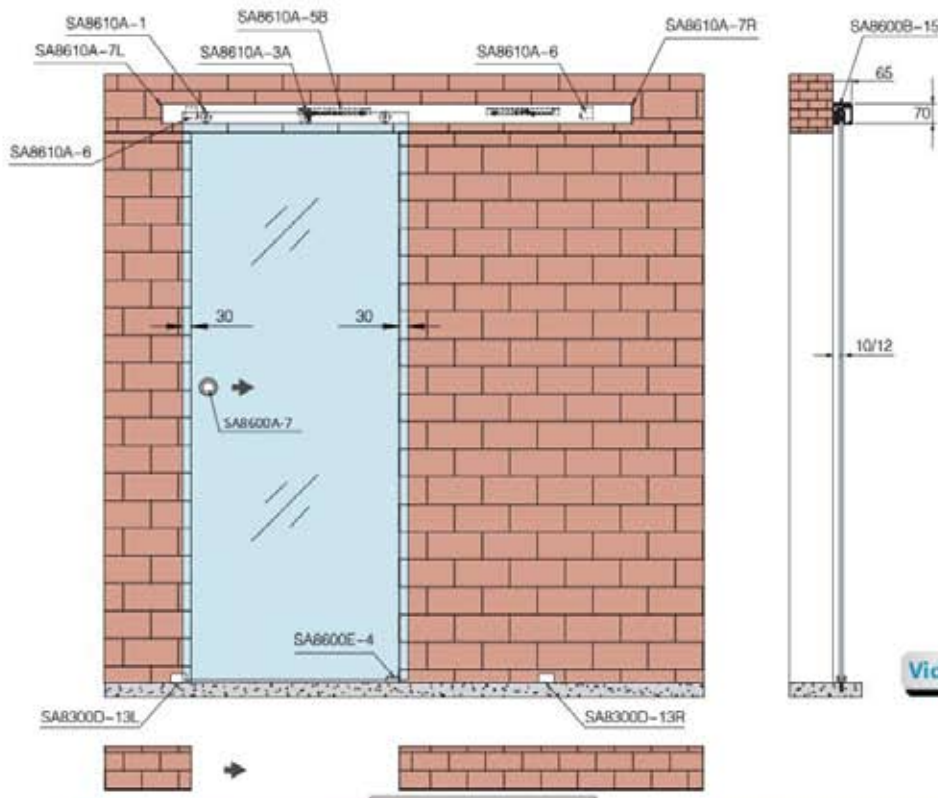

Peso máximo de vidrio **60kg**

Altura máxima de puerta: 2.5 mt

Riel de aluminio 2.5 mts Incluye cobertores en acero inoxidable satinado.

Vidrio de 10-12 mm

Todo viene empacado dentro de un kit con lo necesario para la instalación



CÓDIGO
SA8610A-1DOOR-KIT-SSS

- | | | | | |
|-------------------|-------------------|-------------------|-------------------|----------------------|
| | | | | |
| SA8610A-1 (2PCS) | SA8610A-3C (1PCS) | SA8610A-5B (2PCS) | SA8610A-6 (2PCS) | SA8600A-7 (1PCS) |
| | | | | |
| SA8610A-7L (1PCS) | SA8610A-7R (1PCS) | SA8610E-4 (1PCS) | SA8610B-15 (1PCS) | SA8300D-13L/R (1PCS) |

Riel de 2.5 mts
Con cobertor Inox SSS

Perforaciones en vidrio para sistema SA8610A-1DOOR-KIT-SSS

Requerimientos para instalación con tamaño de 110 mm

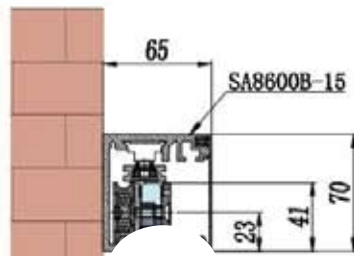
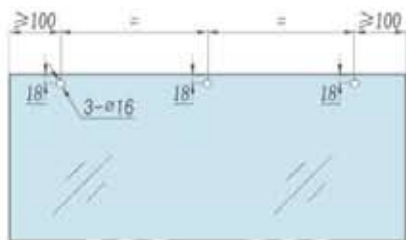

Se puede instalar a pared o techo y comprando los accesorios adicionales se puede instalar a fachadas de vidrio.

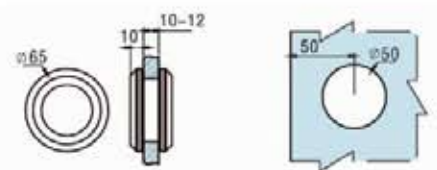

Sistema
TECH-SLIDE 2.0



Sistema
TECH-SLIDE 2.0



Detalles de perforación del vidrio para kit

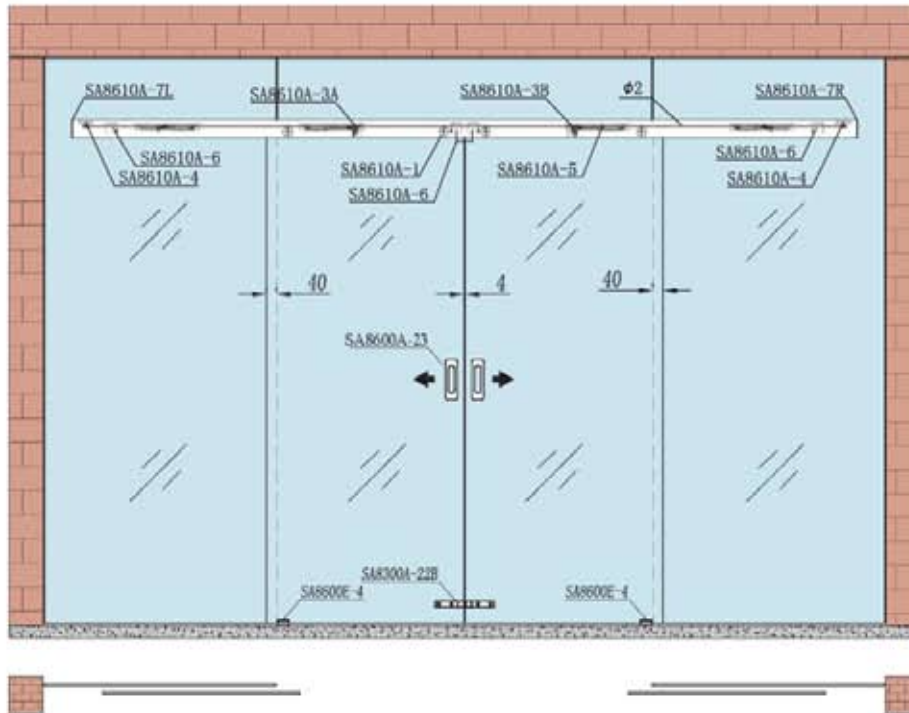

Vidrio de 10-12 mm

Riel de aluminio 3.5 mts Incluye cobertores en acero inoxidable satinado T-304

Peso máximo de cada puerta



Altura máxima de puertas: 2.5 mt

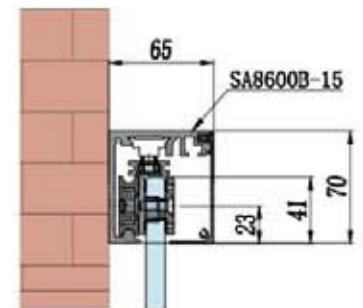

Viene en kit con todo lo necesario para la instalación



SA8610A-1 (4PCS)



SA8610A-3C (1PCS)



SA8610A-3D (1PCS)



SA8610A-4 (2PCS)



SA8600E-4 (2PCS)



SA8610A-5B (4PCS)



SA8610A-6 (4PCS)



SA8610A-7L (1PCS)



SA8610A-7R (1PCS)



SA8600A-23 (2PCS)

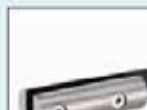

CÓDIGO

SA8610A-2DOOR-KIT-SSS

Se puede instalar a pared o techo como viene en el kit y si compra los accesorios

Detalles de perforación del vidrio para kit

CÓDIGO

SA8610A-2DOOR-KIT-SSS

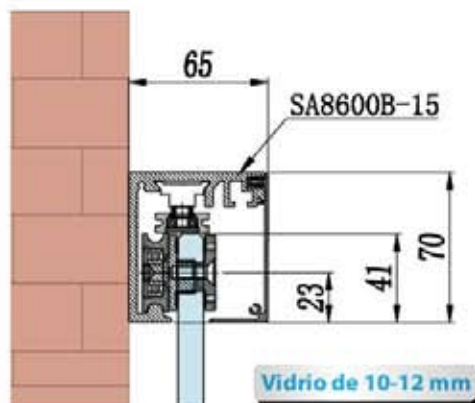

*Este código no se vende por separado, viene dentro del kit.



CÓDIGO

SA8600A-23

Tirador rectangular

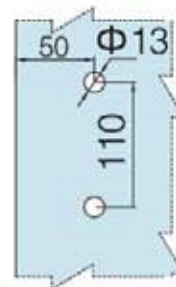
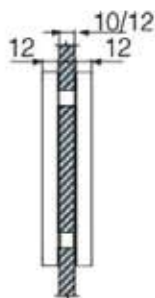
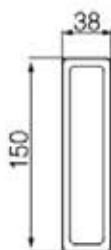

Plano de saques en el vidrio

*Este código no se vende por separado, viene dentro del kit.



CÓDIGO

SA8300A-22B

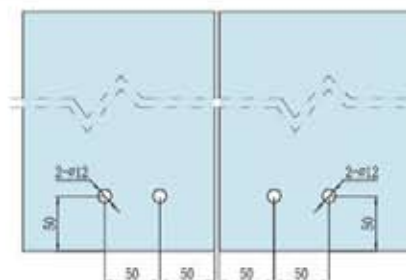
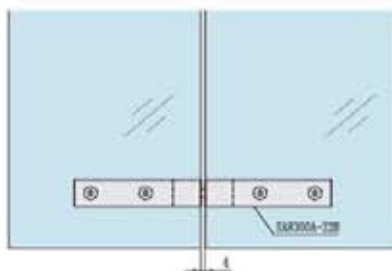



Instalación con panel fijo mediante U channel

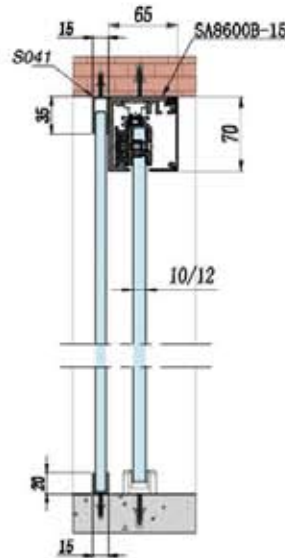

Los kits no incluyen este U channel, se vende por separado.

U channels en aluminio con apariencia inoxidable

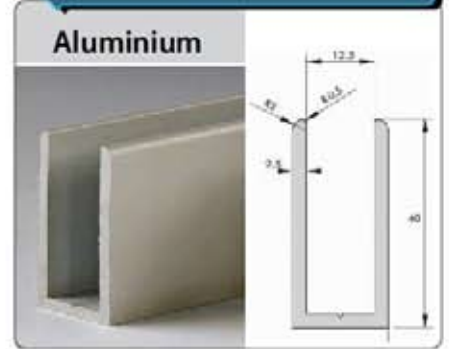

CÓDIGO	ACABADO	LONGITUD
S041	SATINADO	3.5 mts

Kit extra para fijar los sistemas corredizos SA8610A dobles o sencillos a fachadas de vidrio

Se vende por unidad



CÓDIGO
SA8610A-9

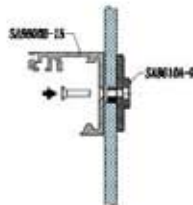

Los kits no incluyen estas piezas, se venden por separado.



CÓDIGO
SA8600B-16

Riel de 3.5 mts
Con cobertor Inox SSS

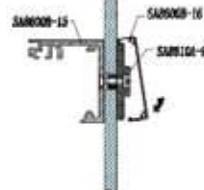
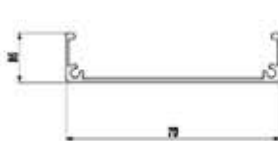

CÓDIGO
SA8610A-8

Tapas para usar con

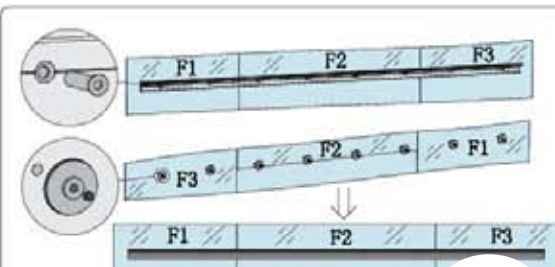

Sarmiento N°1489 - (B1878JDF) Quilmes, Pcia.Bs As.

Celular: +54 (011) 5635-3584

Línea: +54 (011) 7503-0832

<http://formatecsrl.com.ar/>

info@formatecsrl.com.ar